



LC BURNER SERIES





ABOUT US

Limpsfield Combustion is an industrial burner manufacturer, offering complete solutions to combustion requirements from standard burners to individually engineered solutions. Experienced in all common aspects and many more specialised areas of its field, Limpsfield offers experience, quality and competitive prices.

Limpsfield Burners are of an Industrial Forced Draft design, suitable for alternative or simultaneous firing of all types of gaseous fuels and mineral fuel oils. The LC Burner range is available in a number of models with outputs ranging from 3 - 220 MMBtu/hr (0.9 - 62MW).

Designed and manufactured to exacting specifications, the Limpsfield LC burner range is an exceptional combination of form and function. Every feature, from the powder coated finish to the sealed damper bearings and large viewing port, exemplifies the commitment to quality and performance. With the ability to orient both the fuel and air inlets independently of one another the application possibilities are virtually unlimited.

In addition to being easy to set up and adjust, the unique forced draft combustion design distributes the combustion air in the burner head so that the necessary static pressure is maintained for stable combustion and flame geometry, throughout the complete burner firing range. Therefore, the burner achieves less than 3% O₂ throughout the complete firing range making the boiler more efficient with low emissions.



www.Limpsfield.com



BURNER RANGE

Limpsfield Combustion offer standard burners from 3,000,000 Btu/hr (0.9 MW) to 220,000,000 Btu/hr (62 MW), firing a wide range of fuels from natural gas, diesel, #2 oil to heavy fuel oil, waste oils, animal fats, fish oils, bio gases etc. Excellent results have been achieved when firing such fuels offering the end user substantial fuel savings through high performance.

Burner Features



Standard burners have the following features:

- Autoflame burner control system fitted as standard to maximise efficiency, reliability and repeatability of equipment
- Large rear flame viewing port, enabling a unique view of the combustion process
- Fuel inlets on both sides of burner housing offering build flexibility to suit site application
- Simple construction allows easy access to internal components for maintenance. All components can be accessed and replaced without the need to remove the burner from the boiler front
- Stainless steel diffusers and blast tube cones
- Split head combustion manifold design. Adjustable to alter gas injection velocity
- Adjustable gas head/diffuser position for optimum performance
- Multiple fixings on the burner rear section allows fan to be mounted in a variety of different positions to overcome site space restraints
- Remote combustion air fan. Allows forced draught fan to be sized for actual project and sized to meet turndown requirements
- Approved to International Standards



www.Limpsfield.com

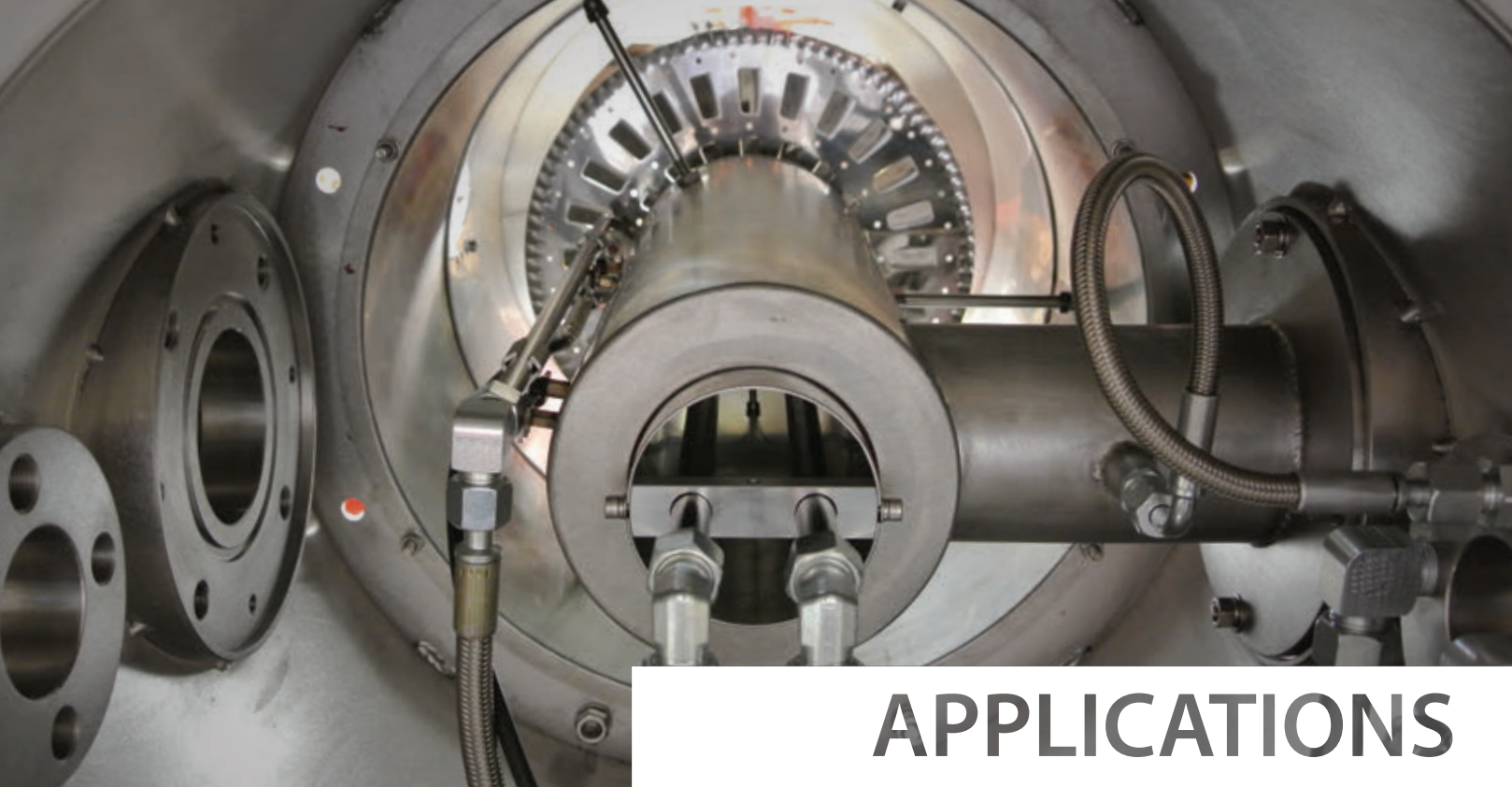

APPLICATIONS

Limpsfield Combustion will engineer a project to suit the customer application whether it is single fuel, dual fuel, multi fuel, change over on the fly between fuels or burning waste stream fuels. The burner can be supplied as a low NOx burner for both gas and oils.

We have carried out many applications to suit our customers' requirements and have extensive experience in firing many fuels in a wide range of applications including fire tube boilers, water tube boilers, kilns, incinerators and dryers.

A selection of typical applications has been listed below:

- Change over on the fly between fuels (no boiler down time between fuel change over)
- Multi fuel firing
- Burning waste stream fuels
- Combined firing of waste stream fuels with a primary fuel
- Six fuels through one burner without hardware changes
- Steam or air atomizing oil lance assembly
- Hydrogen
- Propane
- No6 oil with or without Low NOx
- No4 oil with or without Low NOx
- Methanol
- Isopropanol
- Toluene
- Bio Gas
- Bio Gas / Natural gas blends
- Tallow

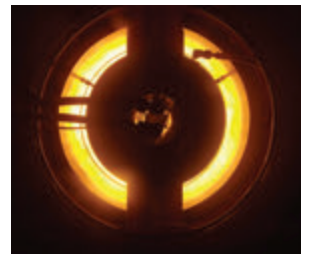
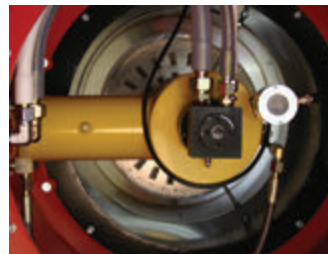

Limpsfield Combustion offers a total engineered solution to meet the site application and specification with high performance and reduced O₂ levels. Contact us for more information.



www.Limpsfield.com



RETROFITS

Limpsfield's engineered solutions enable all burners to be fitted to both new boilers, as well as being retro fitted to existing boilers, allowing fuel savings of up to 35% to be achieved by replacing an existing burner with this high efficiency burner.

The construction of the Limpsfield burner allows it to be easily retro fitted to most boiler types. Some retro-fits, including the Cleaver-Brooks retrofit, use a specifically designed air transitional duct to transfer combustion air from the existing blower wheel assembly located inside the boiler door. Typical turndown ratios of 5:1 and 6:1 on gas firing with O₂ levels less than 3% throughout the firing range make this retro fit have a very quick and realistic return on investment. Many customers have realised savings of 10% - 35% when retro fitting their existing burner with a Limpsfield burner.



TYPICAL BOILER RETROFITS

Aesys Technologies	Garioni Naval	LOOS Boiler	Unilux
Asentec	HB Smith	Nebraska	Universal
Babcock	Hoval Boiler	Ness	Various Kilns
Bigalow	Hurst	Mckenna	Veissman
Bono	ICI	Precision Boilers	Victory Energy
Bosch	Intec	Selnikel	Well Mclain
Broag Rehema	Imeco	Standard Kessel	Welman Robey
Bryan Boilers	Johnston	Strebel	York Shipley
Burnham	Keeler	Sellers Ygnis	力聚锅炉
Bywoth Boiler	Kewanee	Superior	中瑞锅炉
Cleaver-Brooks	Lamount	Simoneau	泰山锅炉
Cochran	Lead/Silver Kettles	Unical	广州天鹿锅炉



www.Limpsfield.com

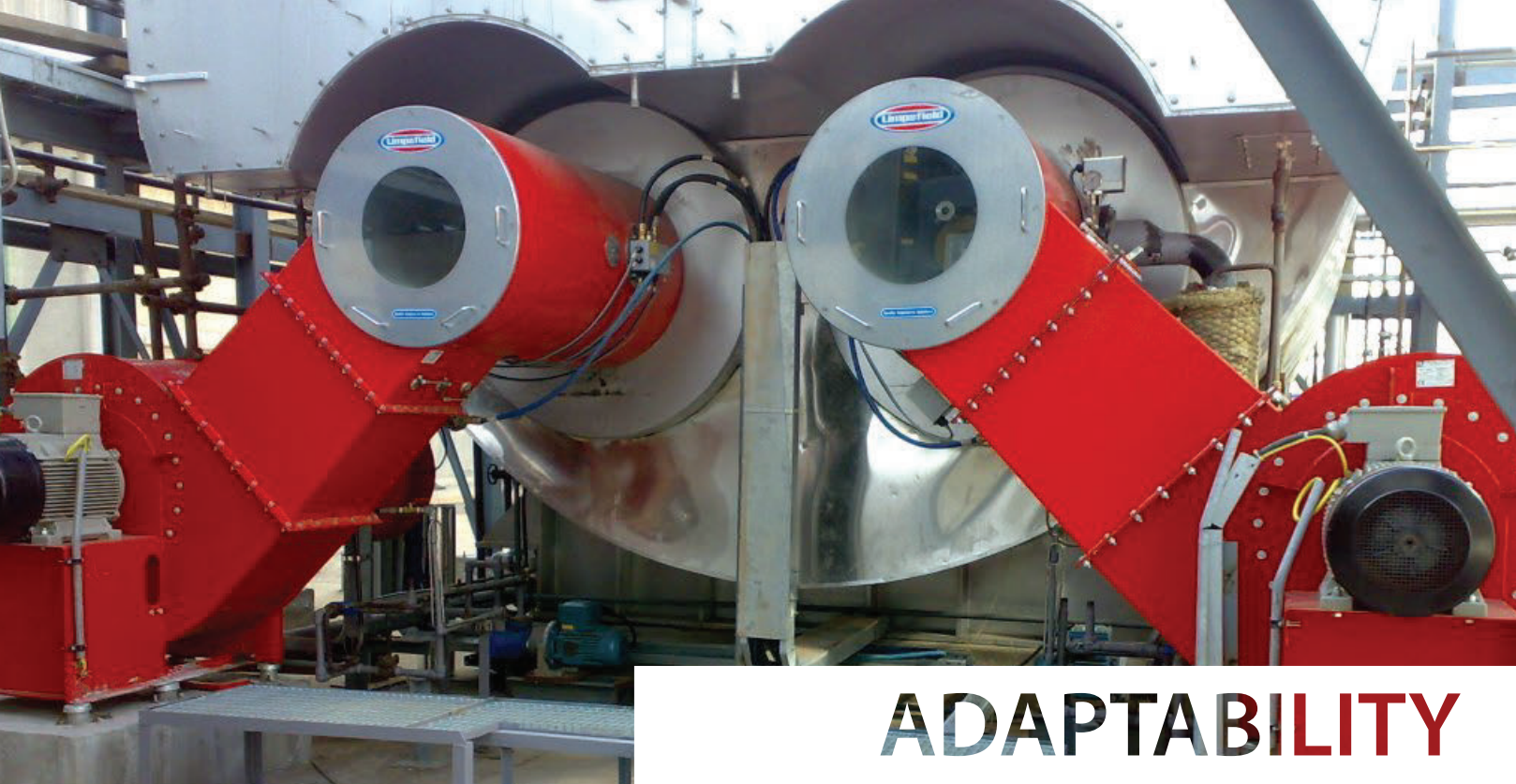

ADAPTABILITY

Combustion air is delivered via a remote or directly mounted centrifugal fan. The fan has a direct coupled, backward curved impeller, and can be supplied with a flange mounted silencer. The air damper blades are operated using fully enclosed bearing assemblies, this allows hysteresis-free operation with infinite repeatability.

The Limpsfield burner is supplied as standard with a split housing which allows the air inlet duct to be rotated 360 degrees in increments of 22.5 degrees, independent of the gas inlets illustrated in the drawings. This feature allows flexibility as to the position of the blower relative to the burner, which may be governed by specific site constraints.

Installation arrangements are limitless. However, for arrangements not shown please contact the factory for consultation in proper air duct design.

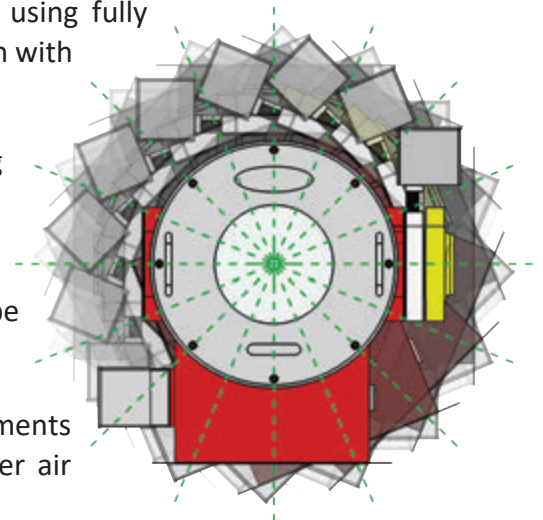

It is recommended that the pressure drop in the air duct between the outlet of the blower and inlet to the burner be no more than $\frac{1}{2}$ " WC.

To properly engineer and ensure job performance, Limpsfield Combustion utilizes a vast array of fan types/sizes from several manufacturers. This allows for proper air delivery in both volume and pressure for installations of high altitude, elevated furnace pressures and varying ambient conditions which affect fan performance. Thus, blower arrangement is dependent upon jobsite conditions, which must be known at the time of placing the order.



www.Limpsfield.com

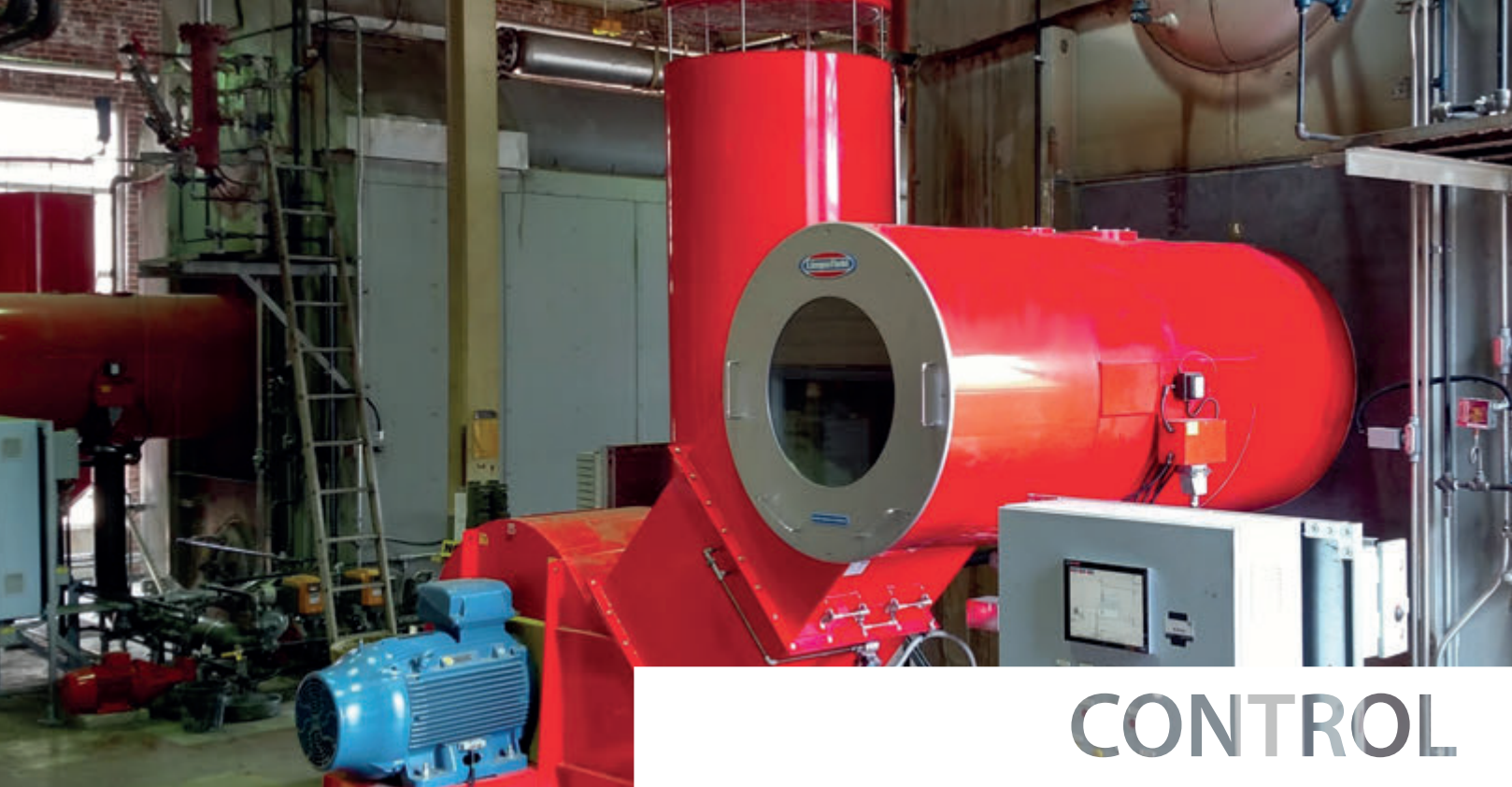

CONTROL

Limpsfield Combustion offers its users control panels to accompany the burners. These are designed and built around advanced combustion control equipment which will further enhance the reliability and performance of the LC burner.

A range of products are available as below:

- Micro Modulation Burner Control units
- EGA with combustion trim functions and CEMS
- Water Level TDS, BBD Control and First Out
- Boiler Sequencing Package



In addition, panel design and specification can be tailored to the end user's specific requirements. All panels are UL approved and built in an ISO9001 environment.

As well as custom designed panels, Limpsfield Combustion also offer UL approved burner mounted control panels to allow users to commission and alter the combustion firing process quickly and easily. This neat package gives customers a more cost-effective option for applications that may not require a fully tailored control panel. The Limpsfield POD mounted burner is available from the LC9 through to the LC100 burner, fitted with a choice of either the Autoflame Mini Mk8 unit or the Autoflame Mk8 touch screen control system.

All options are available as single fuel or dual fuel burners.



www.Limpsfield.com

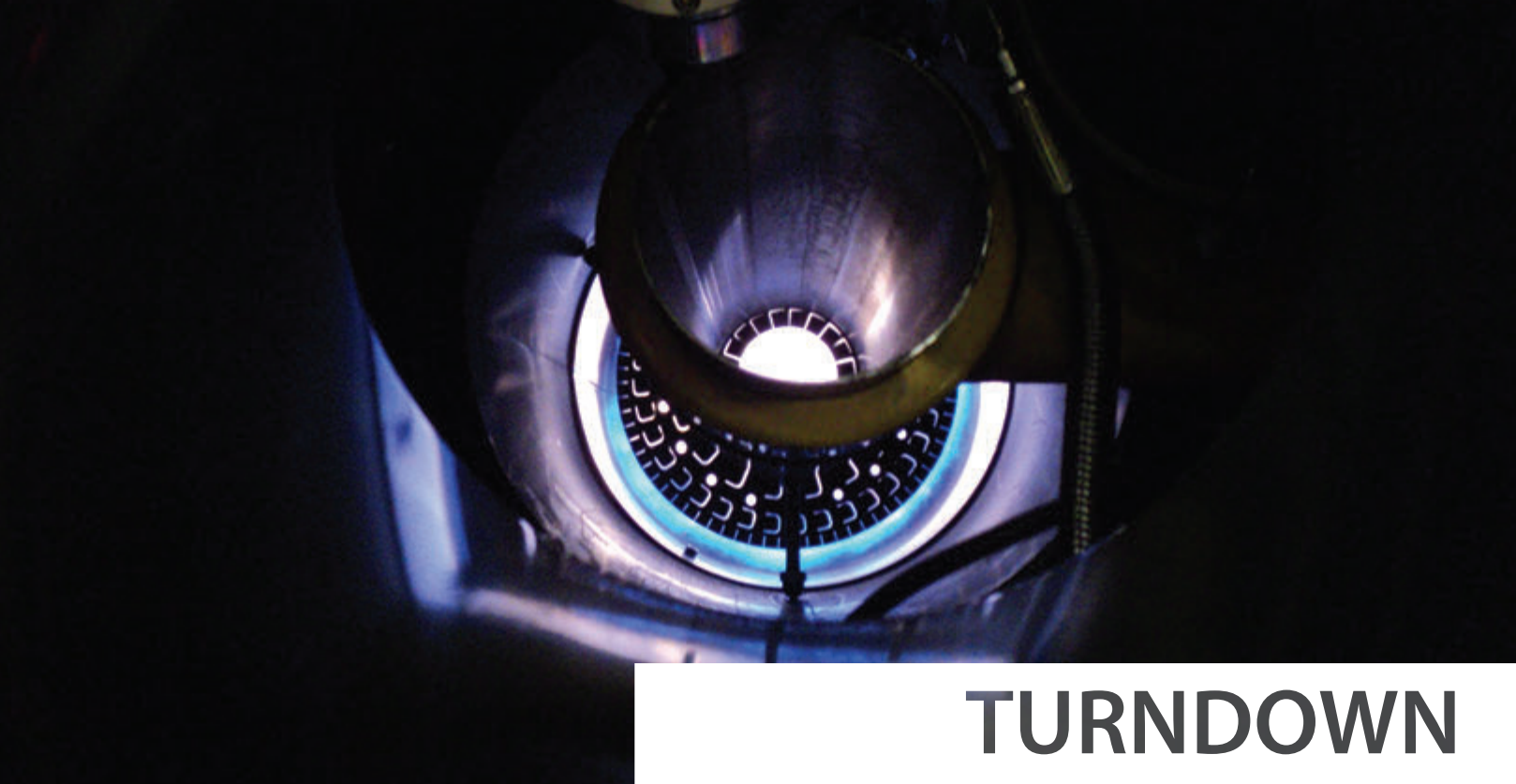

TURNDOWN

Limpsfield burners provide high turndowns typically between 4:1 and 10:1. This turndown is established by using a split gas head or a spider head design. The split gas head can be used on most applications and provides excellent mixing to maintain good combustion throughout the firing range.



The unique spider head assembly offers the user high turn down ratios. It was initially designed to be fired when using fuels with high burning velocities such as Propane or Hydrogen. Unlike the split head, the fuel is introduced after the diffuser plate enabling the flame to establish good retention whilst maintaining excellent mixing. Limpsfield will design and engineer the correct solution to suit your application.

An example of Limpsfield's in-depth engineering capabilities:

This spider head assembly was designed for an application where Hydrogen was produced on-site as a bi-product of a chemical reaction. The heads construction is such that the fuels are supplied from two individual gas trains to separate gas control valves, one on either side of the burner. The two different sizes of main injector are used in order to accommodate the differences in the flame velocity of hydrogen and propane.

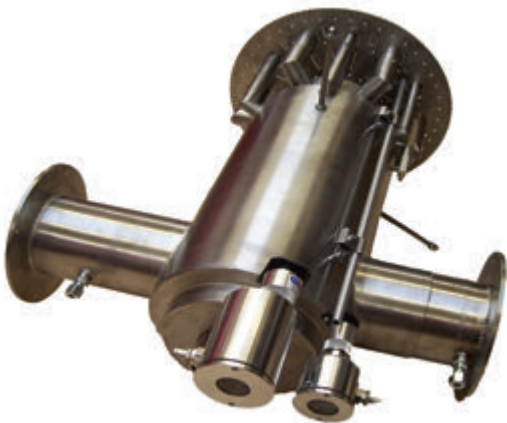

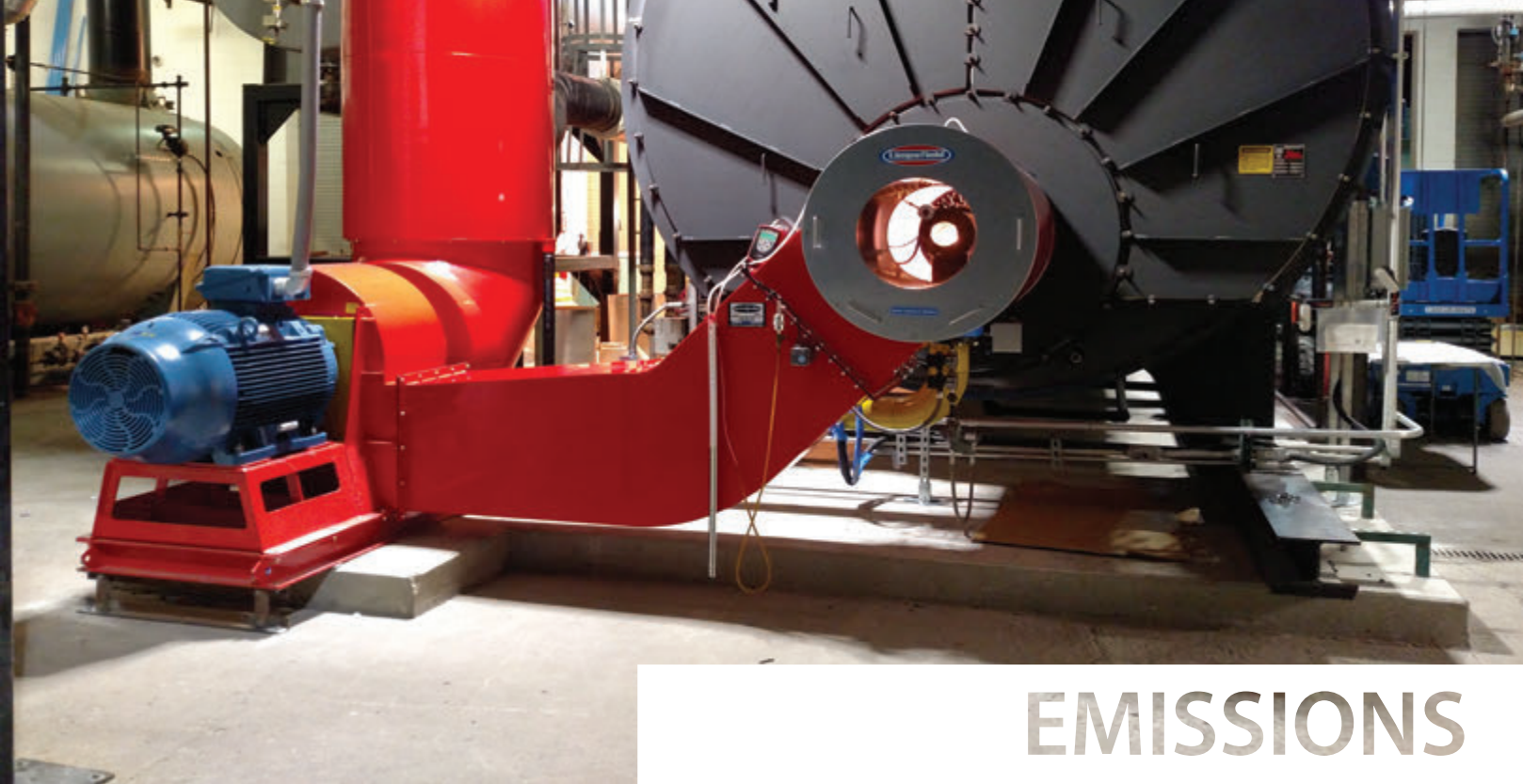

EMISSIONS

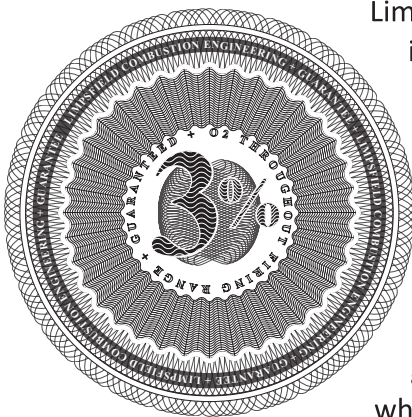

Limpsfield burners have been designed to ensure minimal emissions are released into the atmosphere. This means less harmful emissions are created as well as a greater efficiency of the burner is achieved due to good combustion, which in turn creates great fuel savings. Limpsfield burners are guaranteed to operate at $<3\%$ O_2 and $<10\text{ppm}$ of CO . These figures continue throughout the firing range, from low fire to high fire (when firing natural gas).

Low NO_x burners are available for all sizes of the LC range. These burners are guaranteed to operate at sub 30ppm NO_x whilst maintaining $<3\%$ O_2 and $<10\text{ppm}$ of CO throughout the firing range. More information on the Low NO_x burner options can be seen overleaf.

	Exhaust Gas Analyser						
	Conservation Vals						
	Amb	Exhaust	Delta	Eff %	O_2 %	CO_2 %	CO ppm
High	82 F	253 F	200 F	86.3	2.8	10.1	1.0
Burner 1	82 F	248 F	198 F	86.4	2.8	10.0	1.0
Burner 2	82 F	244 F	194 F	86.5	2.9	10.0	1.0
Burner 3	82 F	246 F	198 F	86.4	2.9	10.0	2.0
Burner 4	82 F	240 F	190 F	86.7	2.8	10.1	1.0
Burner 5	81 F	230 F	183 F	86.9	2.8	10.1	2.0
Burner 6	81 F	229 F	172 F	87.1	2.7	10.1	2.0
Burner 7	81 F	217 F	169 F	87.2	2.7	10.1	2.0
Burner 8	81 F	200 F	154 F	87.5	2.9	10.0	2.0
Burner 9							
Burner 10							
Burner 11							
Burner 12							
Burner 13							
Burner 14							
Burner 15							

Figure: Typical combustion emission values

Limpsfield Combustion is devoted to continuously improving the product to meet and exceed everchanging stringent international emissions regulations.

Detailed research and experiments have taken place during the design process of the Limpsfield burner to ensure the lowest emissions are achieved. Many CFD 'computational fluid dynamics' projects have been completed to gain an accurate representation of the flow and mixing of the gases in the burner.

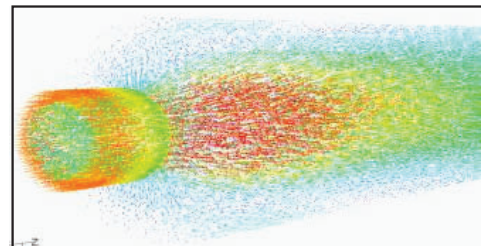
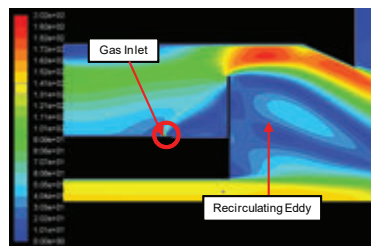
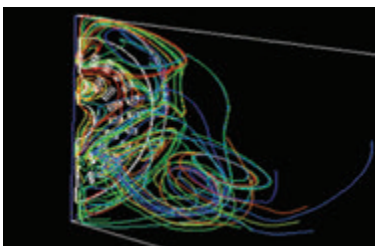



LOW NOx

All Limpsfield LC burners are capable of meeting tough international codes regarding low NOx emissions.

We believe that in order to meet local codes for low NOx requirements, efficiency should not be compromised; therefore, our burners have been designed to operate at a guaranteed sub 30ppm while operating at 3% O₂ or lower throughout the firing range. This is due to the utilisation of flue gas recirculation and the superior flame retention and mixing achievable from the Limpsfield gas head.



Low NOx by flue gas recirculation can be achieved by one of two methods either forced FGR or induced FGR, depending on application. Forced FGR is accomplished by forcing the flue gases with a separate fan back into the combustion zone. Induced FGR draws the flue gases through the combustion air fan. Both methods reduce the bulk flame temperature in the furnace to inhibit the chemical reaction between the nitrogen and oxygen. FGR systems reduce NOx emissions without reducing efficiency.

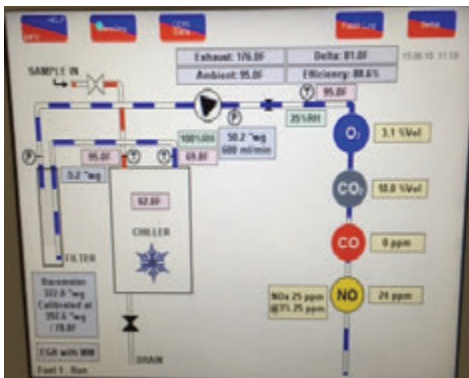

Whether you request 'Forced' or 'Induced' FGR, Limpsfield will engineer a solution to suit the requirements. This will include specifically designing FGR duct work and mixing box assemblies to work within the space available. As standard Limpsfield offer a fully modulating control valve and damper assembly to ensure total control over the FGR mixing prior to the burner.



www.Limpsfield.com



ULTRA LOW NOx

Limpsfield's latest product release is the new Limpsfield ultra low NOx burner, designed to significantly minimize NOx emissions to as low as 9ppm in order to comply with stringent regulations without the need for lengthy conversions.

- Wide firing range: 150,000 Btu/hr (44kW) to 25 MMBtu/hr (7.3mW)
- Sub 9-15ppm NOx emissions
- 3.5% O₂ emissions maintained
- 4:1 turndown from maximum heat input
- Can be run with or without FGR
- Stable flame with or without FGR due to superior mixing
- Premix fuel – uniform flame distribution
- Can be retrofitted to existing Limpsfield burners

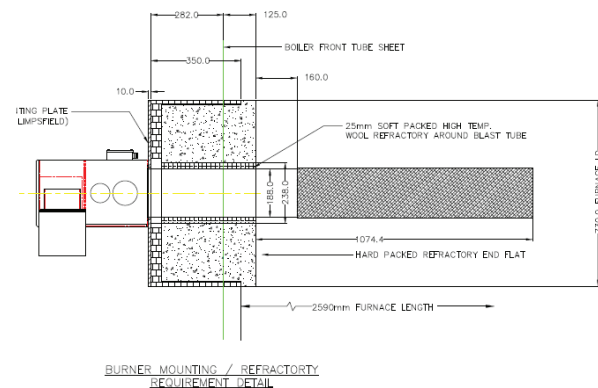
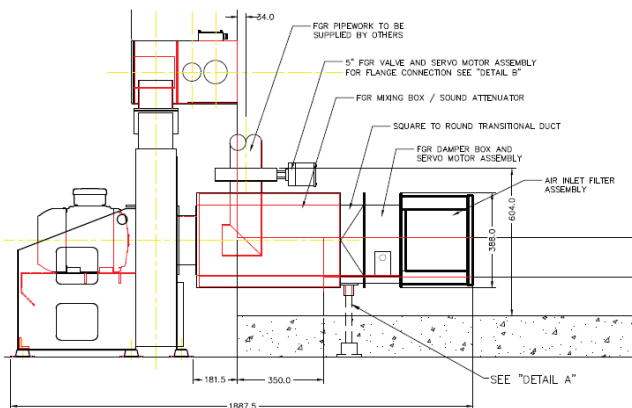
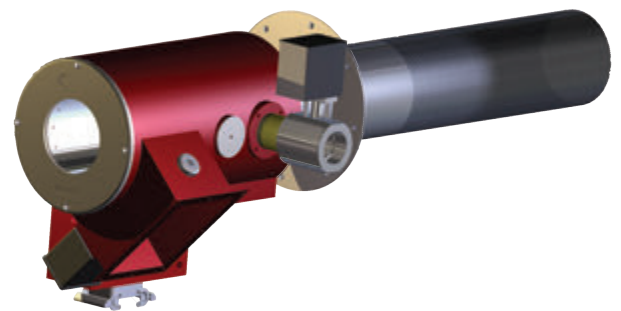

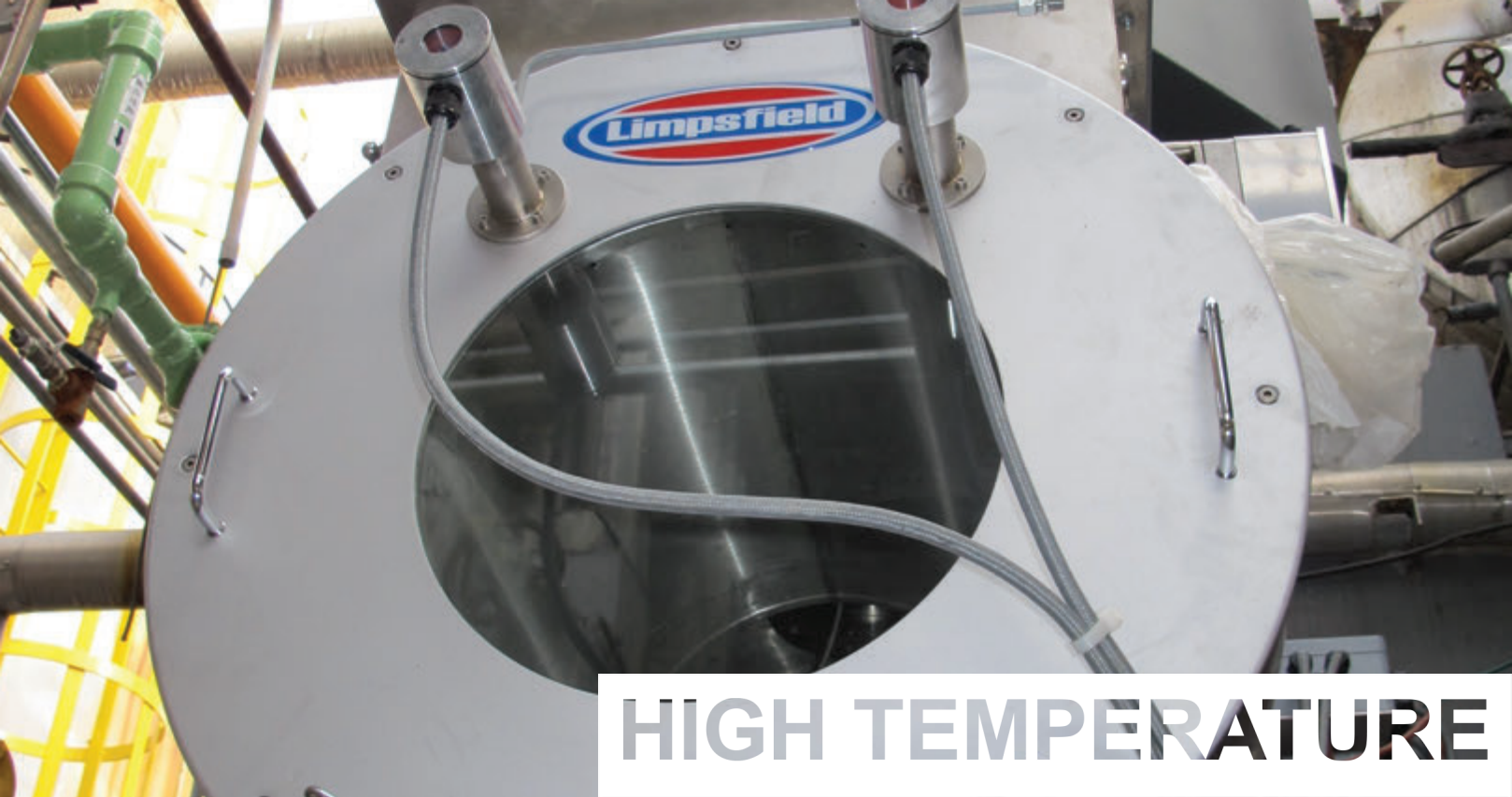

HIGH TEMPERATURE

Pre-heated combustion air

Using hot combustion air can cut fuel consumption. Reducing the temperature difference between outlet flue gas temperature and inlet combustion air temperature by 72 ° F/22° C is said to increase boiler/heater efficiency by 1%.

Another commonly used approach with superheated steam, water tube boiler applications or thermal oil heater is to recover heat from flue gases using a device known as a combustion air preheater.

Limpsfield burner advantages

- Gaseous or liquid fuels
- From 1.7mmbtu (500 KW) with 4 or 6:1 turndown ratio (other upon request)
- Guaranteed 3 % O₂ through the complete firing range
- Up to 428°F/220°C (other upon request)
- Using Stainless Steel and High Temperature Components
- Complete ATEX design available
- Electrical components cooled via compressed air
- Simple Design/Easy to Service – no moving burner parts
- Supplied with Heat Protecting Shroud (up to LC100)
- Available with low NO_x technology



www.Limpsfield.com



WATER TUBE

Limpsfield has a vast amount of experience firing various types and makes of water tube boilers, such as:

- Victory Energy
- B&W
- Cleaver Brooks
- Unilux
- La-Mont
- Keeler
- Garioni Naval
- Nebraska
- Simoneau

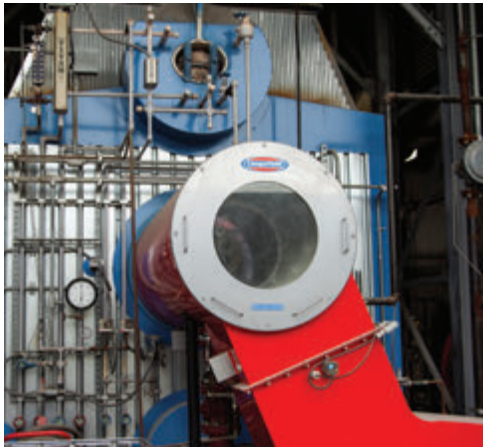

The burner combustion head, whether it be “Split or Spider” gas injection head, provides excellent performance, flame characteristics, turndown ratio and simplicity for these type of applications.

While we guarantee the burner performance @3% O₂ throughout the whole firing range, we can also meet and exceed strict emission requirements, such as sub 30ppm NO_x using FGR (flue gas recirculation).



ENGINEERING

As well as engineering products that can be designed and manufactured in-house, Limpsfield also offer full engineering services for a range of products to compliment Limpsfield burner installs. This can include Gas trains, Gas boosters, Oil pump sets, Oil pre-heating sets and many more.

Gas Trains

Limpsfield can supply gas trains to suit our customers' requirements, whether the application requires natural gas, biogas or other. We offer a range of gas trains, from our standard CE approved version to CSD1 and NFPA 85 to ensure local codes are met, wherever the installation. All of our gas trains are specifically sized to meet the combustion requirements on-site

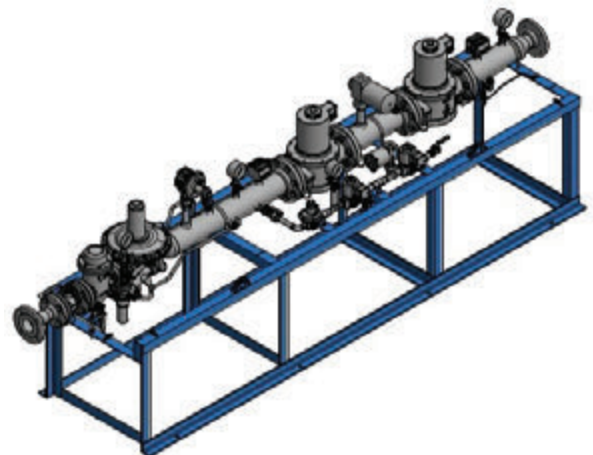

Limpsfield will liaise with the customer to determine the exact requirements. Custom or standard gas train piping schematics are available upon request. Gas trains can be shipped as loose items for assembly on-site, or as one complete pre-fabricated unit.



Oil Pump sets

We offer a range of oil pump sets to suit specific oil types. These can range from light fuel oil through to heavy oils, bio oils or tallow. Pump sets are individually sized to suit the required firing rate and the application it is being used for. Oil pumps are supplied with pressure regulators to ensure a constant supply of pressure to the burner, whether this is Pressure atomizing or Air/ Steam atomizing firing.



www.Limpsfield.com

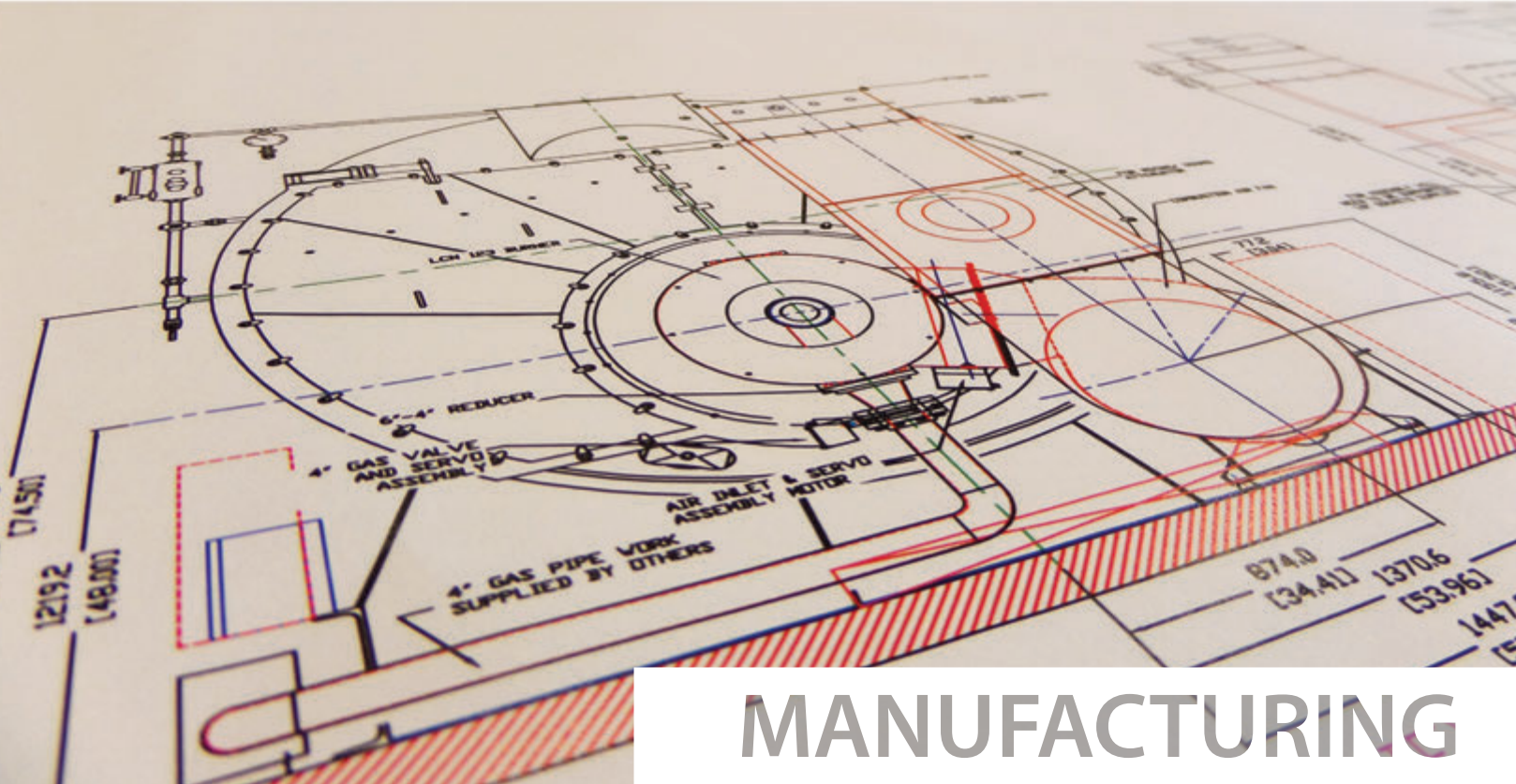

MANUFACTURING

Limpsfield have the capability of creating technical engineering drawings using the latest 2D and 3D Autodesk packages.

Once we have received the site information from our customer we are able to create tailor-made technical drawings specifically for each project. The layout of the burner can be specified to suit on-site conditions. Once complete, these drawings will be sent along with our submittal package for approval. When the project approval has been received, the manufacturing process of the burner will begin. Everything from a simple blanking plate, to a complete stainless steel burner will be manufactured in-house using our state of the art machinery, coded welders and paint shop.

Machining and fabrication capabilities:

- Bystronic Bystar 3015kW Fibre laser cutting machine
- Bystronic CNC Expert 100 folder
- Amada Guillotine
- Mig and Tig welding – certificated welders
- Various rollers/swaging machines and pillar drills
- Pemsarter for press studs/bushes and fixings
- Silver soldering capabilities
- Brazing capabilities
- Chemical degreasing unit for pre-painting preparation
- In-house wet spraying facilities
- In-house powder coating facilities
- 2 off Mazak QTNX 250-2 MSY machines complete with magazine bar feeds and rota-rack parts unloader
- 3 off Mazak 530C Milling machine with Mazatrol Matrix 2 controls
- Mazak 350MSY Quick Turn Smooth Technology
- Schenck Balancing and Measuring Unit Cab820



www.Limpsfield.com



COMPONENTS

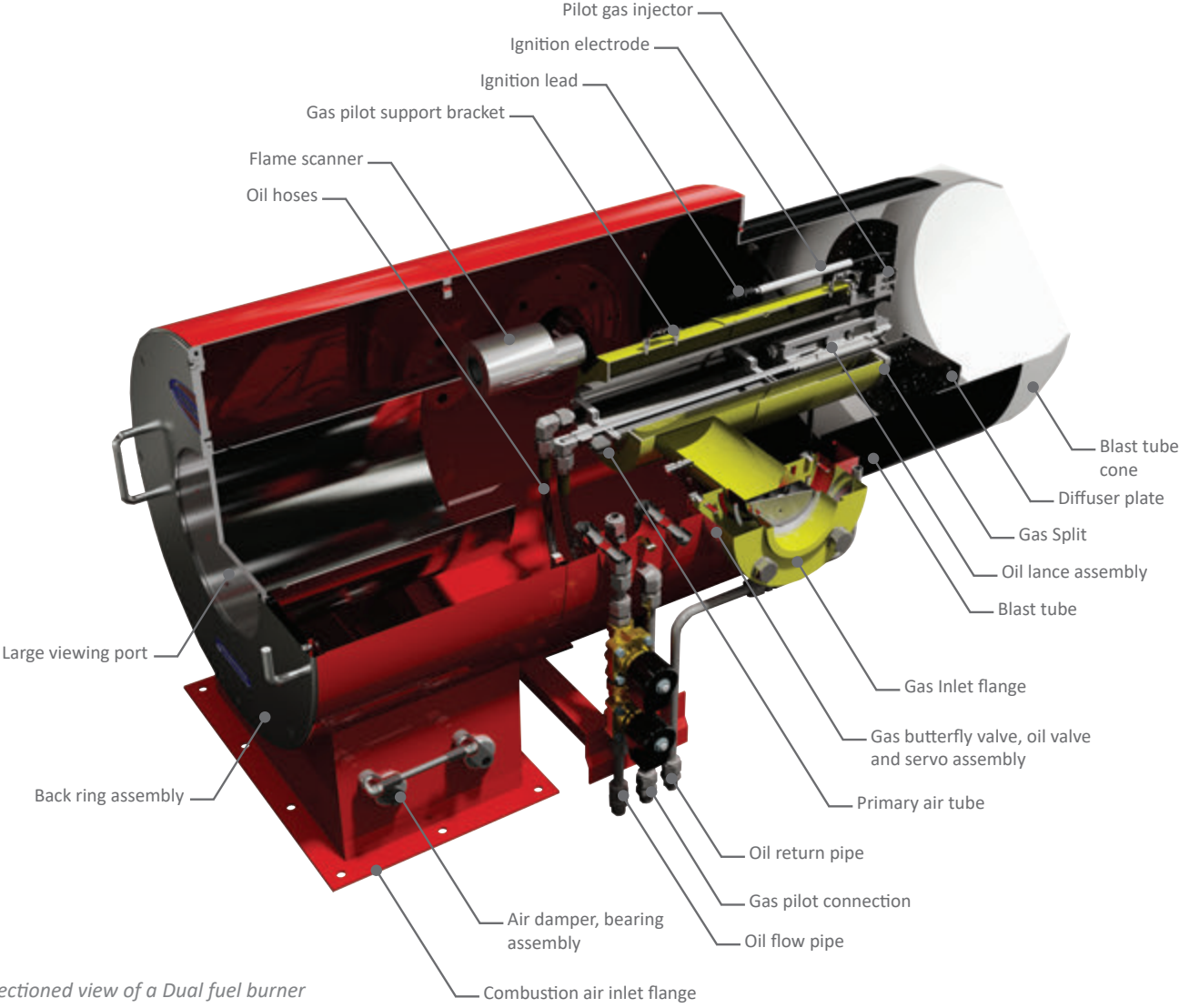

Figure: Sectioned view of a Dual fuel burner





TECHNICAL DATA

Limpsfield burner model numbers can be determined as follows;



N = Natural Gas K = Kerosene P = Propane Gas
 O = #2 Fuel Oil T = Tallow BG = Bio Gas
 HO = #6 Fuel Oil H = Hydrogen WG = Waste Gas

Burner Model Number	Units	9	15	21	25	30	36	44	53	62	73	88	100	123	150	175	200	263	310	390	450	550	620
Burner Rating	MMBtu	3	5	7	8.3	10	12.3	15	18	21	25	30	35	42	50	60	70	90	110	135	160	190	220
Air at 15% Excess	Cuft/hr	33,465	55,775	78,085	94,818	117,128	137,206	167,325	200,790	234,255	278,875	334,650	390,425	468,510	557,750	669,300	780,850	1,003,950	1,227,050	1,505,925	1,784,800	2,119,450	2,454,100
Air + FGR @62.9°C / 145.22°F	Cuft/hr	41,831	69,718	97,606	118,522	146,409	171,507	209,156	250,987	292,818	348,593	418,312	488,031	585,637	697,187	836,625	976,062	1,254,937	1,533,812	1,882,406	2,231,000	2,649,313	3,067,625
No.2 Oil input rate (137,080 btu/gal)	GPH (US)	21.9	36.5	51.1	62.0	76.6	89.7	109.4	131.1	153.2	183.4	218.9	255.3	306.4	364.8	437.7	510.7	656.6	802.5	1009.6	1164.9	1423.8	1605.0
Gas input rate (1000 btu/cuft)	Cuft/hr	3,000	5,000	7,000	8,500	10,500	12,300	15,000	18,000	21,000	25,000	30,000	35,000	42,000	50,000	60,000	70,000	90,000	110,000	135,000	150,000	190,000	220,000
Minimum Pilot pressure	"WG	12	12	12	12	12	12	12	12	12	12	12	12	12	12	12	12	12	12	12	12	12	12
Delta P Air	"WG	7	10	11	12	12	12	12	12	12	12	12	12	12	12	12	12	12	12	12	12	12	12
Delta P Air + FGR	"WG	10.5	15	16.5	18	18	18	18	18	18	18	18	18	18	18	18	18	18	18	18	18	18	18
Blast tube O.D	Inches	6.92	7.44	10	10.19"	11.10"	11.77	12.36	14.21	15.19	16.41	17.95	19.29	21.25	22.91	25.11	27.04	30.53	33.53	36.53	39.8	43.54	46.88
Gas Inlet	NPT	2"	2"	2.5"	2.5"	2.5"	2.5"	2.5"	3"	3"	4"	4"	4"	6"	6"	6"	6"	8"	8"	10"	10"	10"	10"
Mounting P.C.D	Inches	9.45	9.45	13.97	13.97	13.97	13.97	13.97	17.32	17.32	22.44	22.44	22.44	30.9	30.9	30.9	30.9	39.31	39.31	55.18	55.18	55.18	55.18
Mounting hole ø	Inches	0.33	0.33	0.41	0.41	0.41	0.41	0.41	0.41	0.41	0.67	0.67	0.67	0.55	0.55	0.55	0.55	0.82	0.82	1.02	1.02	1.02	1.02
Quantity of mounting holes		4	4	8	8	8	8	8	8	8	8	8	8	12	12	12	12	8	8	10	10	10	10



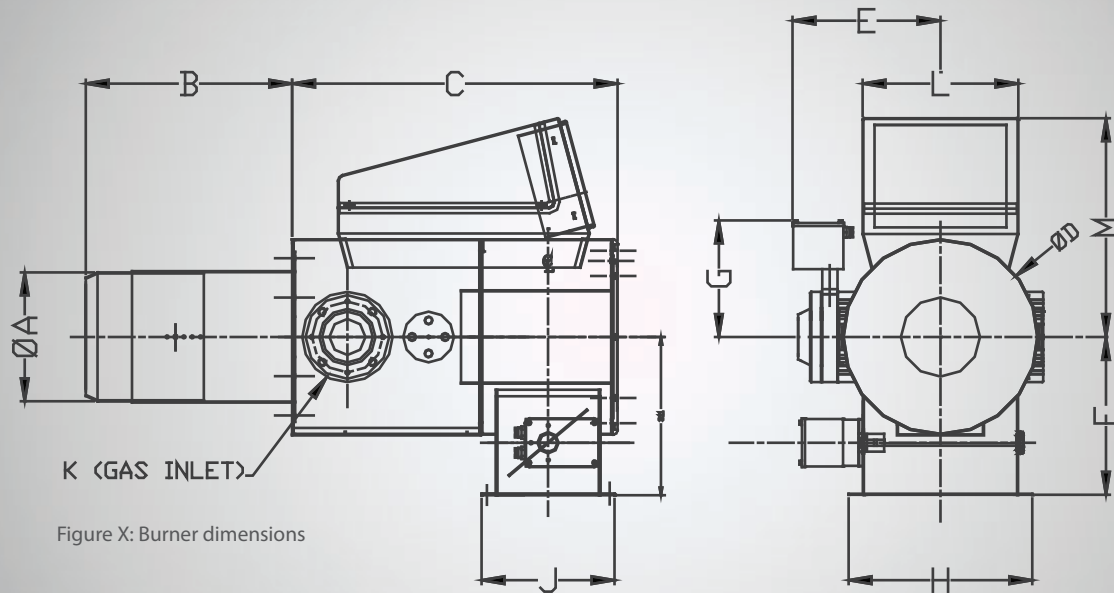

Figure X: Burner dimensions

DIMENSIONS

Burner Model Number	A	B	C	D	E	F	G	H	J	K	Mini Mk8		Mk8	
											L	M	L	M
All dimension in mm and (inches) unless stated otherwise														
9	177 (6.97)	210 (8.27)	435 (17.13)	260 (10.24)	394 (15.51)	212 (8.35)	170 (6.69)	244 (9.60)	180 (7.09)	2" NPT	210 (8.27)	296 (11.65)	N/A	N/A
15	189 (7.44)	210 (8.27)	435 (17.13)	260 (10.24)	394 (15.51)	212 (8.35)	170 (6.69)	244 (9.60)	180 (7.09)	2" NPT	210 (8.27)	296 (11.65)	N/A	N/A
21	259 (10.19)	406 (15.98)	642 (25.28)	385 (15.16)	455 (17.91)	311 (12.24)	170 (6.69)	362 (14.25)	242 (9.53)	2.5" 150lb	210 (8.27)	359 (14.13)	307 (12.09)	431 (16.97)
25	268 (10.55)	406 (15.98)	642 (25.28)	385 (15.16)	455 (17.91)	311 (12.24)	170 (6.69)	362 (14.25)	242 (9.53)	2.5" 150lb	210 (8.27)	359 (14.13)	307 (12.09)	431 (16.97)
30	291 (11.46)	406 (15.98)	642 (25.28)	385 (15.16)	455 (17.91)	311 (12.24)	170 (6.69)	362 (14.25)	242 (9.53)	2.5" 150lb	210 (8.27)	359 (14.13)	307 (12.09)	431 (16.97)
36	299 (11.77)	408 (16.06)	642 (25.28)	385 (15.16)	455 (17.91)	311 (12.24)	170 (6.69)	362 (14.25)	242 (9.53)	2.5" 150lb	210 (8.27)	359 (14.13)	307 (12.09)	431 (16.97)
44	316 (12.44)	408 (16.06)	642 (25.28)	385 (15.16)	455 (17.91)	311 (12.24)	170 (6.69)	362 (14.25)	262 (10.31)	2.5" 150lb	210 (8.27)	359 (14.13)	307 (12.09)	431 (16.97)
53	361 (14.21)	428 (16.85)	703 (27.68)	480 (18.90)	572 (22.52)	347 (13.66)	240 (9.45)	430 (16.93)	298 (11.73)	3" 150lb	210 (8.27)	406 (15.98)	307 (12.09)	479 (18.86)
62	386 (15.19)	464 (18.27)	703 (27.68)	480 (18.90)	572 (22.52)	347 (13.66)	240 (9.45)	430 (16.93)	298 (11.73)	3" 150lb	210 (8.27)	406 (15.98)	307 (12.09)	479 (18.86)
73	412 (16.22)	556 (21.89)	814 (32.05)	630 (24.80)	721 (28.39)	460 (18.11)	253 (9.96)	550 (21.65)	396 (15.59)	4" 150lb	N/A	N/A	307 (12.09)	566 (22.28)
88	456 (17.95)	575 (22.64)	814 (32.05)	630 (24.80)	721 (28.39)	460 (18.11)	253 (9.96)	550 (21.65)	396 (15.59)	4" 150lb	N/A	N/A	307 (12.09)	566 (22.28)
100	490 (19.29)	595 (23.43)	814 (32.05)	630 (24.80)	721 (28.39)	460 (18.11)	253 (9.96)	550 (21.65)	396 (15.59)	4" 150lb	N/A	N/A	307 (12.09)	566 (22.28)
123	540 (21.26)	726 (28.58)	1205 (47.44)	838 (33.00)	942 (37.09)	561 (22.09)	264 (10.39)	721 (28.39)	594 (23.39)	6" 150lb	N/A	N/A	N/A	N/A
150	582 (22.91)	766 (30.16)	1205 (47.44)	838 (33.00)	942 (37.09)	561 (22.09)	264 (10.39)	721 (28.39)	594 (23.39)	6" 150lb	N/A	N/A	N/A	N/A
175	638 (25.12)	783 (30.83)	1205 (47.44)	838 (33.00)	942 (37.09)	561 (22.09)	264 (10.39)	721 (28.39)	594 (23.39)	6" 150lb	N/A	N/A	N/A	N/A
200	699 (27.52)	809 (31.85)	1205 (47.44)	838 (33.00)	942 (37.09)	561 (22.09)	264 (10.39)	721 (28.39)	594 (23.39)	6" 150lb	N/A	N/A	N/A	N/A
263	776 (30.55)	986 (38.81)	1608 (63.31)	1055 (41.54)	1187 (46.73)	731 (28.78)	314.8 (12.39)	893 (35.17)	710 (27.95)	8" 150lb	N/A	N/A	N/A	N/A
310	864 (34.02)	1035 (40.75)	1608 (63.31)	1055 (41.54)	1187 (46.73)	731 (28.78)	314.8 (12.39)	893 (35.17)	710 (27.95)	8" 150lb	N/A	N/A	N/A	N/A
390	944 (37.16)	1239 (48.78)	2163 (85.16)	1506 (59.29)	1526 (60.08)	1028 (40.47)	355 (13.98)	1248 (49.13)	1008 (39.69)	10" 150lb	N/A	N/A	N/A	N/A
450	1027 (40.43)	1285 (50.59)	2163 (85.16)	1506 (59.29)	1526 (60.08)	1028 (40.47)	355 (13.98)	1248 (49.13)	1008 (39.69)	10" 150lb	N/A	N/A	N/A	N/A
550	1122 (44.17)	1365 (53.74)	2163 (85.16)	1506 (59.29)	1526 (60.08)	1028 (40.47)	355 (13.98)	1248 (49.13)	1008 (39.69)	10" 150lb	N/A	N/A	N/A	N/A
620	1207 (47.52)	1285 (50.59)	2163 (85.16)	1506 (59.29)	1526 (60.08)	1028 (40.47)	355 (13.98)	1248 (49.13)	1008 (39.69)	10" 150lb	N/A	N/A	N/A	N/A

* Please contact Limpsfield for more information



www.Limpsfield.com



Limpsfield Combustion is in partnership with more than 50 technology centres worldwide. To maintain our reputation for quality, safety and reliability, we ensure they receive regular training to keep up to date with our latest innovations.

Our burner range is UL, cUL and CE approved. As a company we are also ISO9001:2015 approved. This means that our Quality Management System is audited internally and externally at regular intervals to ensure Limpsfield continue to produce products of the highest quality.





www.Limpsfield.com



Rep:

Limpsfield Combustion Engineering Co. Limited
Unit 7 Concorde Business Centre,
Airport Industrial Estate,
Main Road,
Biggin Hill,
Kent,
TN16 3YN
United Kingdom

 +44 (0)1959 576 633

 Limpsfield Combustion
Engineering

 sales@limpsfield.co.uk

 www.limpsfield.co.uk